**Pneumatic fluid power — Cylinders,
1 000 kPa (10 bar) series — Mounting
dimensions of rod-end clevises**

*Transmissions pneumatiques — Vérins, série à 1 000 kPa (10 bar) —
Dimensions d'interchangeabilité des chapes d'extrémité de tige*





COPYRIGHT PROTECTED DOCUMENT

© ISO 2018

All rights reserved. Unless otherwise specified, or required in the context of its implementation, no part of this publication may be reproduced or utilized otherwise in any form or by any means, electronic or mechanical, including photocopying, or posting on the internet or an intranet, without prior written permission. Permission can be requested from either ISO at the address below or ISO's member body in the country of the requester.

ISO copyright office
CP 401 • Ch. de Blandonnet 8
CH-1214 Vernier, Geneva
Phone: +41 22 749 01 11
Fax: +41 22 749 09 47
Email: copyright@iso.org
Website: www.iso.org

Published in Switzerland

Licensed to: Forsythe, Allison Mrs
Downloaded: 2023-07-19
Single user licence only, copying and networking prohibited

Contents

	Page
Foreword	iv
Introduction	v
1 Scope	1
2 Normative references	1
3 Terms and definitions	1
4 Mounting dimensions	1
5 Application instructions	3
5.1 Installation.....	3
5.2 Lubrication.....	3
6 Example of ordering designation	3
7 Identification statement (reference to this document)	3
Bibliography	4

Foreword

ISO (the International Organization for Standardization) is a worldwide federation of national standards bodies (ISO member bodies). The work of preparing International Standards is normally carried out through ISO technical committees. Each member body interested in a subject for which a technical committee has been established has the right to be represented on that committee. International organizations, governmental and non-governmental, in liaison with ISO, also take part in the work. ISO collaborates closely with the International Electrotechnical Commission (IEC) on all matters of electrotechnical standardization.

The procedures used to develop this document and those intended for its further maintenance are described in the ISO/IEC Directives, Part 1. In particular the different approval criteria needed for the different types of ISO documents should be noted. This document was drafted in accordance with the editorial rules of the ISO/IEC Directives, Part 2 (see www.iso.org/directives).

Attention is drawn to the possibility that some of the elements of this document may be the subject of patent rights. ISO shall not be held responsible for identifying any or all such patent rights. Details of any patent rights identified during the development of the document will be in the Introduction and/or on the ISO list of patent declarations received (see www.iso.org/patents).

Any trade name used in this document is information given for the convenience of users and does not constitute an endorsement.

For an explanation on the voluntary nature of standards, the meaning of ISO specific terms and expressions related to conformity assessment, as well as information about ISO's adherence to the World Trade Organization (WTO) principles in the Technical Barriers to Trade (TBT) see the following URL: www.iso.org/iso/foreword.html.

This document was prepared by Technical Committee ISO/TC 131, *Fluid power systems*, Subcommittee SC 3, *Cylinders*.

This fourth edition cancels and replaces the third edition (ISO 8140:2009), which has been technically revised.

The changes compared to the previous edition are as follows:

- The normative references have been updated.
- [Figure 1](#) has been corrected, dimensioning of ER starts at the centerline of the hole in the right view.

Any feedback or questions on this document should be directed to the user's national standards body. A complete listing of these bodies can be found at www.iso.org/members.html.

Introduction

In pneumatic fluid power systems, power is transmitted and controlled through a gas under pressure within a circuit.

One component of such systems is the pneumatic fluid power cylinder. This is a device that converts power into linear mechanical force and motion. It consists of a movable element, i.e. a piston and piston rod, operating within a cylindrical bore.

Pneumatic fluid power — Cylinders, 1 000 kPa (10 bar) series — Mounting dimensions of rod-end clevises

1 Scope

This document specifies the mounting dimensions required for interchangeability of rod-end clevises of pneumatic cylinders. The rod-end clevises have been designed specifically for use with 1 000 kPa [10 bar¹⁾] series cylinders manufactured in accordance with ISO 6432 and ISO 15552, but this does not limit their application.

The clevises are used on piston rods of pneumatic cylinders for mechanically transmitting the cylinder force. The design of the clevises is based on the maximum forces resulting from the specified internal diameter of the cylinders and pressure according to ISO 6432, ISO 15552 and ISO 21287.

2 Normative references

The following documents are referred to in the text in such a way that some or all of their content constitutes requirements of this document. For dated references, only the edition cited applies. For undated references, the latest edition of the referenced document (including any amendments) applies.

ISO 5598, *Fluid power systems and components — Vocabulary*

ISO 6099, *Fluid power systems and components — Cylinders — Identification code for mounting dimensions and mounting types*

3 Terms and definitions

For the purposes of this document, the terms and definitions given in ISO 5598 apply.

ISO and IEC maintain terminological databases for use in standardization at the following addresses:

- IEC Electropedia: available at <http://www.electropedia.org/>
- ISO Online browsing platform: available at <http://www.iso.org/obp>

4 Mounting dimensions

The identification code for mounting dimensions and mounting types is in accordance with ISO 6099.

See [Figure 1](#) and [Table 1](#) for mounting dimensions.

1) 1 bar = 100 kPa = 10⁵ Pa, 1 Pa = 1 N/m².

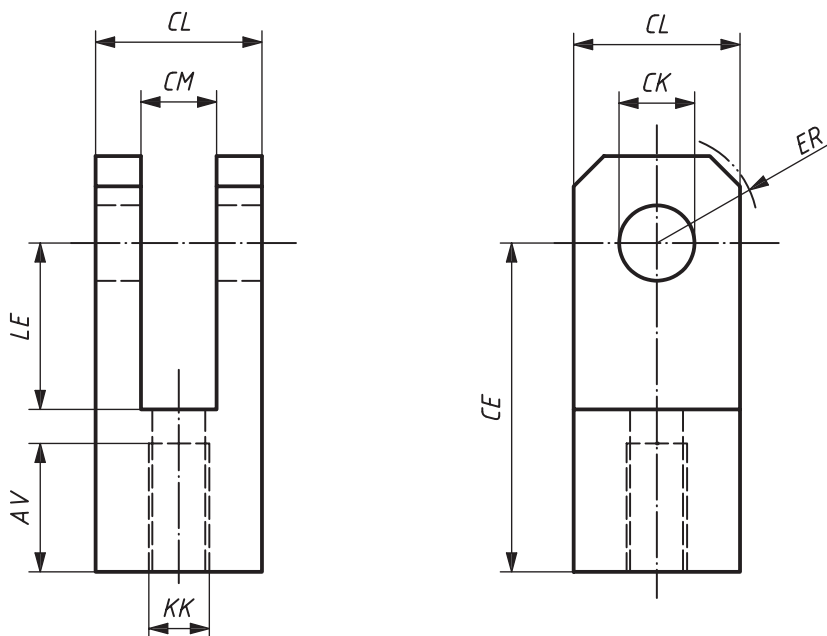

Figure 1 — AP2 — Rod clevis

Table 1 — Dimensions of AP2 — Rod clevis

Dimensions in millimetres

KK	AV min.	CK H9	CE	CL max.	CM		LE min.	ER max.
						tol.		
M4	8	4	16	8	4	+0,4 +0,1	8	6,5
M6	12	6	24	12	6	+0,4 +0,1	12	9,5
M8	16	8	32	16	8	+0,50 +0,15	16	13
M10 × 1,25	20	10	40	20	10	+0,50 +0,15	20	16
M12 × 1,25	22	12	48	24	12	+0,50 +0,15	24	19
M16 × 1,5	28	16	64	32	16	+0,50 +0,15	32	25
M20 × 1,5	33	20	80	40	20	+0,60 +0,15	40	32
M27 × 2	51	30	110	55	30	+0,60 +0,15	54	45
M36 × 2	56	35	144	70	35	+0,60 +0,15	72	57
M42 × 2	60	40	168	85	40	+0,60 +0,15	84	77
M48 × 2	65	50	192	96	50	+0,60 +0,15	96	88

Licensed to: Forsythe, Allison Mrs

Downloaded: 2023-07-19

Single user licence only, copying and networking prohibited

5 Application instructions

5.1 Installation

5.1.1 The tolerance of f8 (see ISO 286-2) is recommended for the bearing shaft.

5.1.2 The rod and clevis shall be locked with a locking nut.

5.2 Lubrication

5.2.1 Sufficient lubrication shall be provided for the satisfactory performance of the rod-end clevises.

5.2.2 The method and frequency of such lubrication depend on the particular operating conditions.

6 Example of ordering designation

A rod-end clevis with a bore of $CK = 20$ mm shall be designated as follows:

AP2 ISO 8140:—, 20

7 Identification statement (reference to this document)

It is strongly recommended to manufacturers who have chosen to conform to this document that the following statement be used in test reports, catalogues and sales literature:

“Pneumatic cylinder rod-end clevis mounting dimensions in accordance with ISO 8140: —, Pneumatic fluid power — Cylinders, 1 000 kPa (10 bar) series — Mounting dimensions of rod-end clevises.”

Bibliography

- [1] ISO 286-2, *Geometrical product specifications (GPS) — ISO code system for tolerances on linear sizes — Part 2: Tables of standard tolerance classes and limit deviations for holes and shafts*
- [2] ISO 6432, *Pneumatic fluid power — Single rod cylinders, 1 000 kPa (10 bar) series, bores from 8 mm to 25 mm — Basic and mounting dimensions*
- [3] ISO 15552, *Pneumatic fluid power — Cylinders with detachable mountings, 1 000 kPa (10 bar) series, bores from 32 mm to 320 mm — Basic, mounting and accessories dimensions*
- [4] ISO 21287, *Pneumatic fluid power — Cylinders — Compact cylinders, 1 000 kPa (10 bar) series, bores from 20 mm to 100 mm*

