**Pneumatic fluid power — Cylinders
with detachable mountings,
1 000 kPa (10 bar) series, bores from
32 mm to 320 mm — Basic, mounting
and accessories dimensions**

*Transmissions pneumatiques — Vérins avec fixations détachables,
série 1 000 kPa (10 bar), alésages de 32 mm à 320 mm — Dimensions
de base, des fixations et des accessoires*





COPYRIGHT PROTECTED DOCUMENT

© ISO 2018

All rights reserved. Unless otherwise specified, or required in the context of its implementation, no part of this publication may be reproduced or utilized otherwise in any form or by any means, electronic or mechanical, including photocopying, or posting on the internet or an intranet, without prior written permission. Permission can be requested from either ISO at the address below or ISO's member body in the country of the requester.

ISO copyright office
CP 401 • Ch. de Blandonnet 8
CH-1214 Vernier, Geneva
Phone: +41 22 749 01 11
Fax: +41 22 749 09 47
Email: copyright@iso.org
Website: www.iso.org

Published in Switzerland

Licensed to: Hade, Allison
Downloaded: 2023-04-18
Single user licence only, copying and networking prohibited

Contents

	Page
Foreword	iv
Introduction	v
1 Scope	1
2 Normative references	1
3 Terms and definitions	1
4 Dimensions	1
4.1 Basic dimensions.....	1
4.2 Mounting dimensions.....	1
4.3 Accessories dimensions.....	2
5 Nominal stroke	2
6 Bore sizes	2
7 Mounting types	3
8 Accessory types	3
9 Product designation codes	3
10 Identification statement (reference to this document)	3
Bibliography	18

Foreword

ISO (the International Organization for Standardization) is a worldwide federation of national standards bodies (ISO member bodies). The work of preparing International Standards is normally carried out through ISO technical committees. Each member body interested in a subject for which a technical committee has been established has the right to be represented on that committee. International organizations, governmental and non-governmental, in liaison with ISO, also take part in the work. ISO collaborates closely with the International Electrotechnical Commission (IEC) on all matters of electrotechnical standardization.

The procedures used to develop this document and those intended for its further maintenance are described in the ISO/IEC Directives, Part 1. In particular the different approval criteria needed for the different types of ISO documents should be noted. This document was drafted in accordance with the editorial rules of the ISO/IEC Directives, Part 2 (see www.iso.org/directives).

Attention is drawn to the possibility that some of the elements of this document may be the subject of patent rights. ISO shall not be held responsible for identifying any or all such patent rights. Details of any patent rights identified during the development of the document will be in the Introduction and/or on the ISO list of patent declarations received (see www.iso.org/patents).

Any trade name used in this document is information given for the convenience of users and does not constitute an endorsement.

For an explanation on the voluntary nature of standards, the meaning of ISO specific terms and expressions related to conformity assessment, as well as information about ISO's adherence to the World Trade Organization (WTO) principles in the Technical Barriers to Trade (TBT) see the following URL: www.iso.org/iso/foreword.html.

This document was prepared by Technical Committee ISO/TC 131, *Fluid power systems*, Subcommittee SC 3, *Cylinders*.

This second edition cancels and replaces the first edition (ISO 15552:2004), which has been technically revised.

The main changes made are:

- Symbols for the accessory types have been made to be the same as the symbols in ISO 6099;
- Characteristics of the piston rod were added to 4.1;
- Product designation codes were added;
- The port size for each piston bore diameter was added to "Basic dimensions".

Introduction

In pneumatic fluid power systems, power is transmitted and controlled through a gas under pressure within a circuit.

One component of such systems is the pneumatic cylinder. This is a device which converts power into linear mechanical force and motion. It consists of a movable element, i.e. a piston, and a piston rod, operating within a cylindrical bore.

To enable them to be fastened to user mechanisms, pneumatic cylinders comprise, in addition, some devices called “mountings”.

Pneumatic fluid power — Cylinders with detachable mountings, 1 000 kPa (10 bar) series, bores from 32 mm to 320 mm — Basic, mounting and accessories dimensions

1 Scope

This document establishes a metric series of basic, mounting and accessories dimensions as required for interchangeability of single or double rod pneumatic cylinders with or without provision for magnetic sensors for a maximum rated pressure of 1 000 kPa (10 bar).

It applies to pneumatic cylinders with detachable mountings.

2 Normative references

The following documents are referred to in the text in such a way that some or all of their content constitutes requirements of this document. For dated references, only the edition cited applies. For undated references, the latest edition of the referenced document (including any amendments) applies.

ISO 273, *Fasteners — Clearance holes for bolts and screws*

ISO 3320, *Fluid power systems and components — Cylinder bores and piston rod diameters and area ratios — Metric series*

ISO 4393, *Fluid power systems and components — Cylinders — Basic series of piston strokes*

ISO 4395, *Fluid power systems and components — Cylinder piston rod end types and dimensions*

ISO 5598, *Fluid power systems and components — Vocabulary*

ISO 16030, *Pneumatic fluid power — Connections — Ports and stud ends*

3 Terms and definitions

For the purposes of this document, the terms and definitions given in ISO 5598 apply.

ISO and IEC maintain terminological databases for use in standardization at the following addresses:

- IEC Electropedia: available at <http://www.electropedia.org/>
- ISO Online browsing platform: available at <https://www.iso.org/obp>

4 Dimensions

4.1 Basic dimensions

The basic dimensions are given in [Tables 2](#) and [3](#) and shown in [Figures 2](#) and [3](#). The piston rod diameter shall be larger than the thread diameter (KK) to have a shouldered male thread end.

4.2 Mounting dimensions

The mounting dimensions are given in [Tables 4](#) to [9](#) and shown in [Figures 4](#) to [9](#).

The sign + after letters means that the stroke is to be added to the actual dimension.

4.3 Accessories dimensions

The accessories dimensions are given in [Tables 10 to 14](#) and shown in [Figures 10 to 14](#).

The tolerances of dimensions dependent on stroke included in the tables apply for strokes up to and including 1 250 mm. If strokes are longer than 1 250 mm, tolerances should be selected from national standards or by agreement between the manufacturer and user.

5 Nominal stroke

5.1 The nominal strokes shall be selected from the recommended values given in ISO 4393.

5.2 The nominal stroke tolerances are given in [Table 1](#) and shown in [Figure 1](#).

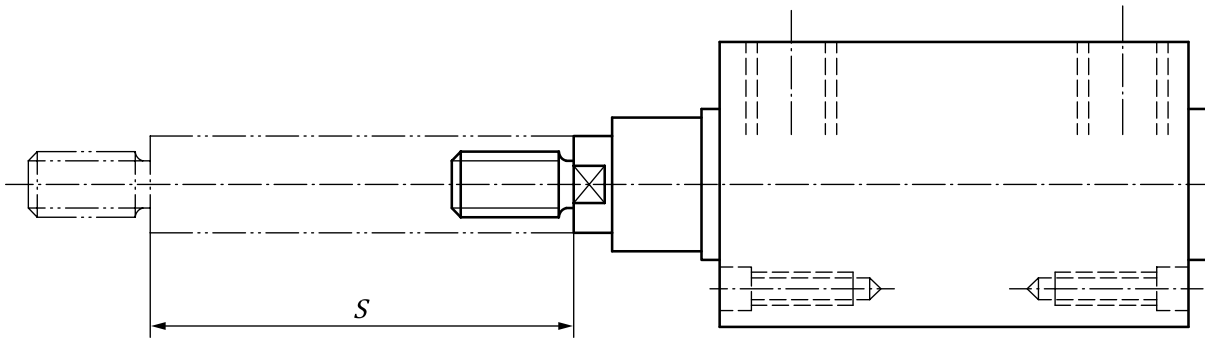

Figure 1 — Nominal stroke tolerances

Table 1 — Nominal stroke tolerances

Dimensions in millimetres

Bore <i>AL</i>	Nominal stroke <i>S</i>	Nominal stroke tolerance ^a
32 40 50	$S \leq 500$	+2 0
	$500 < S \leq 1\ 250$	+3,2 0
63 80 100	$S \leq 500$	+2,5 0
	$500 < S \leq 1\ 250$	+4 0
125 160 200 250 320	$S \leq 500$	+4 0
	$500 < S \leq 1\ 250$	+5 0

^a See [4.3](#), paragraph 2.

6 Bore sizes

Included in this series are the following bore sizes AL in accordance with ISO 3320:

32 – 40 – 50 – 63 – 80 – 100 – 125 – 160 – 200 – 250 – 320 (in millimetres)

7 Mounting types

This document includes the following mounting types as described in ISO 6099:

- MF1 Head, rectangular flange (see [Table 4](#) and [Figure 4](#));
- MF2 Cap, rectangular flange (see [Table 4](#) and [Figure 4](#));
- MP2 Cap, detachable clevis (see [Table 5](#) and [Figure 5](#));
- MP4 Cap, detachable plain eye (see [Table 6](#) and [Figure 6](#));
- MP6 Cap, detachable eye with spherical bearing (see [Table 7](#) and [Figure 7](#));
- MS1 End angles (see [Table 8](#) and [Figure 8](#));
- MT4 Intermediate trunnion (male) fixed or mobile (see [Table 9](#) and [Figure 9](#)).

8 Accessory types

This document includes the following accessory types as described in ISO 6099:

- AA4-R Pivot pin plain (cotter pin or snap ring type) (see [Table 10](#) and [Figure 10](#));
- AA4-S Pivot pin plain (split pins) (see [Table 10](#) and [Figure 10](#));
- AA6-R Pivot pin, spherical bearing (cotter pin or snap ring type) (see [Table 11](#) and [Figure 11](#));
- AA6-S Pivot pin, spherical bearing (split pins) (see [Table 11](#) and [Figure 11](#));
- AB6 Clevis bracket, spherical eye, straight (see [Table 12](#) and [Figure 12](#));
- AB7 Eye bracket, in angle (see [Table 13](#) and [Figure 13](#));
- AT4 Trunnion bracket (see [Table 14](#) and [Figure 14](#)).

9 Product designation codes

A pneumatic cylinder with detachable mountings, mounting type = MT 4, bore = 80 mm, stroke = 200 mm, shall be designated as follows:

ISO 15552 – MT 4 – 80×200

10 Identification statement (reference to this document)

Use the following statement in test reports, catalogues, and sales literature when electing to comply with this document:

Basic, mounting and accessories dimensions of pneumatic cylinder according to ISO 15552 “*Pneumatic fluid power — Cylinders with detachable mountings, 1 000 kPa (10 bar) series, bores from 32 mm to 320 mm — Basic, mounting and accessories dimensions*”.

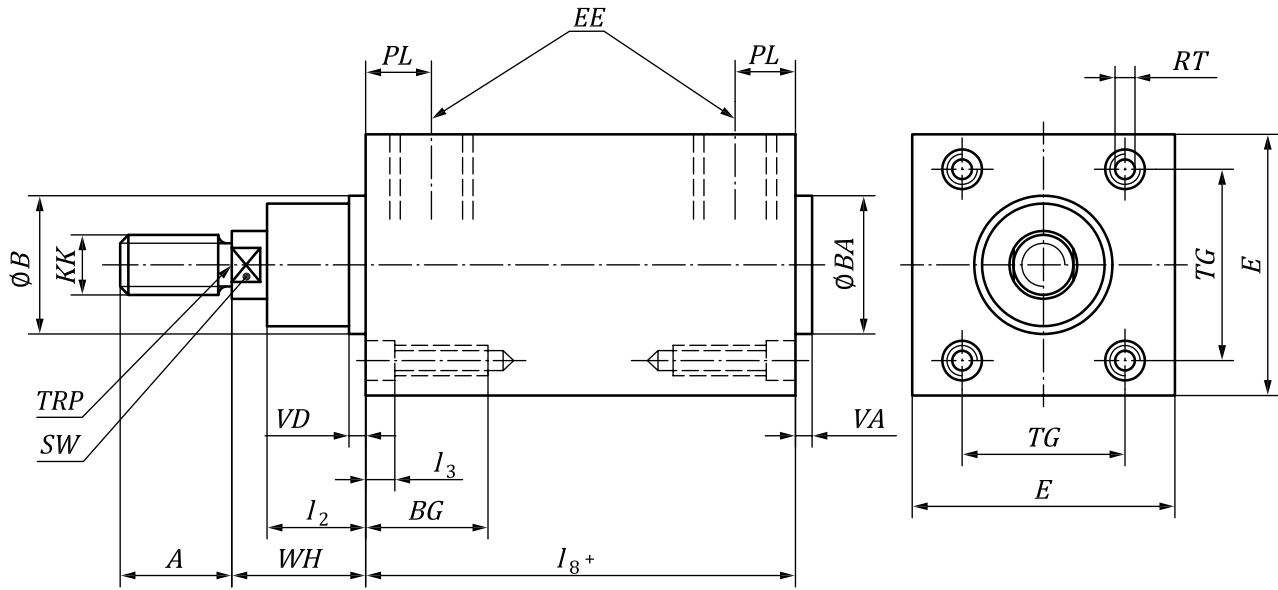

Key
TRP theoretical reference point

Figure 2 — Basic dimensions — Single rod cylinder

The connecting port and the cushion adjusting screw is placed on the same side as the port connection. The cushion adjusting screw has to be located within dimension *E*.

Table 2 — Basic dimensions — Single rod cylinder

Dimensions in millimetres

AL	EE ^b	A	B BA	BG	E	KK ^a	l ₂		l ₃	l ₈		PL	RT	SW	TG		VA	VD	WH	
							nom	tol		max	nom				tol	min			nom	tol
32	G1/8"	22	30	16	50	M10 × 1,25	20	0 -5	5	94	±0,4	13	M6	10	32,5	±0,5	4	4	26	±1,4
40	G1/4"	24	35	16	58	M12 × 1,25	22		5	105	±0,7	14	M6	13	38	±0,5	4	4	30	±1,4
50	G1/4"	32	40	16	70	M16 × 1,5	29		5	106	±0,7	14	M8	17	46,5	±0,6	4	4	37	±1,4
63	G3/8"	32	45	16	85	M16 × 1,5	29		5	121	±0,8	16	M8	17	56,5	±0,7	4	4	37	±1,8
80	G3/8"	40	45	17	105	M20 × 1,5	35		0	128	±0,8	16	M10	22	72	±0,7	4	4	46	±1,8
100	G1/2"	40	55	17	130	M20 × 1,5	38		0	138	±1	18	M10	22	89	±0,7	4	4	51	±1,8
125	G1/2"	54	60	20	157	M27 × 2	50	0 -10	0	160	±1	18	M12	27	110	±1,1	6	6	65	±2,2
160	G3/4"	72	65	24	195	M36 × 2	60		0	180	±1,1	25	M16	36	140	±1,1	6	6	80	±2,2
200	G3/4"	72	75	24	238	M36 × 2	70	0 -15	0	180	±1,6	25	M16	36	175	±1,1	6	6	95	±2,2
250	G1"	84	90	25	290	M42 × 2	80		0	200	±1,6	31	M20	46	220	±1,5	10	10	105	±2,2
320	G1"	96	110	28	353	M48 × 2	90		0	220	±2,2	31	M24	55	270	±1,5	10	10	120	±2,2

^a According to ISO 4395.

^b According to ISO 16030.

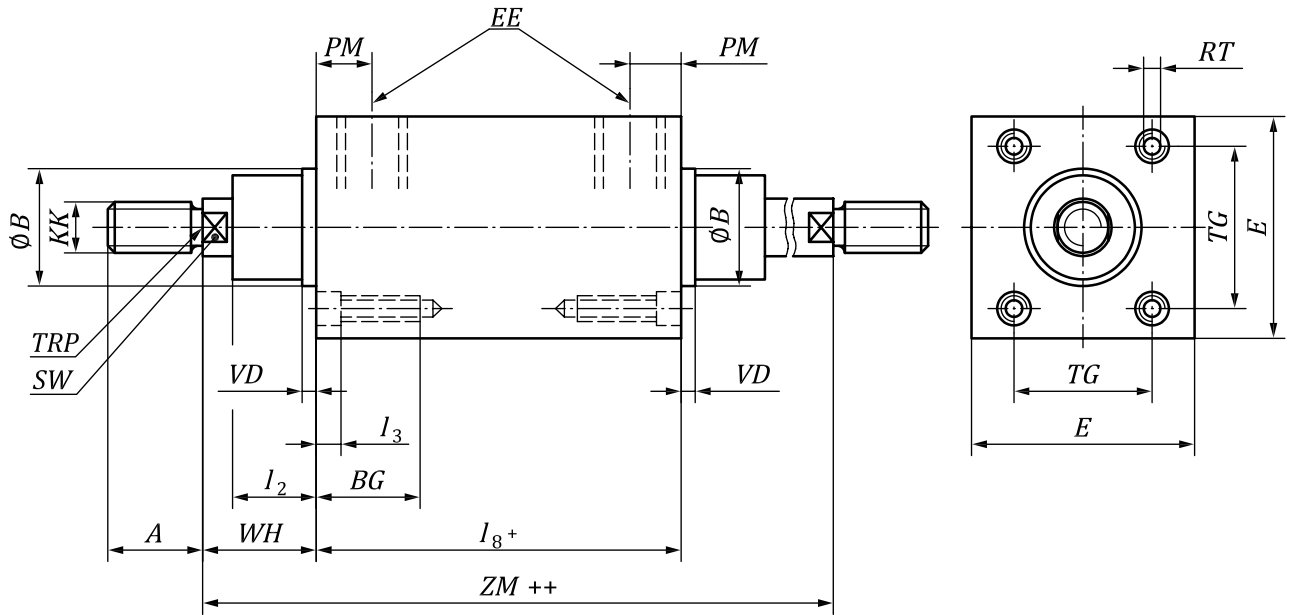

Key
 TRP theoretical reference point

Figure 3 — Basic dimensions — Double rod cylinder

The connecting port and the cushion adjusting screw is placed on the same side as the port connection. The cushion adjusting screw has to be located within dimension E .

Table 3 — Basic dimensions — Double rod cylinder

AL	EE ^b	A	B	BG	E	KK ^a	l ₂		l ₃	l ₈		PM	RT	SW	TG		VD	WH		ZM	
							nom	tol		max	nom				tol	nom		tol	min	nom	tol
32	G1/8"	22	30	16	50	M10 × 1,25	20	0 -5	5	94	±0,4	13	M6	10	32,5	±0,5	4	26	±1,4	146	+3, -1,5
40	G1/4"	24	35	16	58	M12 × 1,25	22		5	105	±0,7	14	M6	13	38	±0,5	4	30	±1,4	165	
50	G1/4"	32	40	16	70	M16 × 1,5	29		5	106	±0,7	14	M8	17	46,5	±0,6	4	37	±1,4	180	
63	G3/8"	32	45	16	85	M16 × 1,5	29		5	121	±0,8	16	M8	17	56,5	±0,7	4	37	±1,8	195	
80	G3/8"	40	45	17	105	M20 × 1,5	35		0	128	±0,8	16	M10	22	72	±0,7	4	46	±1,8	220	
100	G1/2"	40	55	17	130	M20 × 1,5	38		0	138	±1	18	M10	22	89	±0,7	4	51	±1,8	240	
125	G1/2"	54	60	20	157	M27 × 2	50	0 -10	0	160	±1	18	M12	27	110	±1,1	6	65	±2,2	290	+3,5 -2
160	G3/4"	72	65	24	195	M36 × 2	60		0	180	±1,1	25	M16	36	140	±1,1	6	80	±2,2	340	
200	G3/4"	72	75	24	238	M36 × 2	70	0 -15	0	180	±1,6	25	M16	36	175	±1,1	6	95	±2,2	370	+4,5 -2,5
250	G1"	84	90	25	290	M42 × 2	80		0	200	±1,6	31	M20	46	220	±1,5	10	105	±2,2	410	
320	G1"	96	110	28	353	M48 × 2	90		0	220	±2,2	31	M24	55	270	±1,5	10	120	±2,2	460	

^a According to ISO 4395.
^b According to ISO 16030.

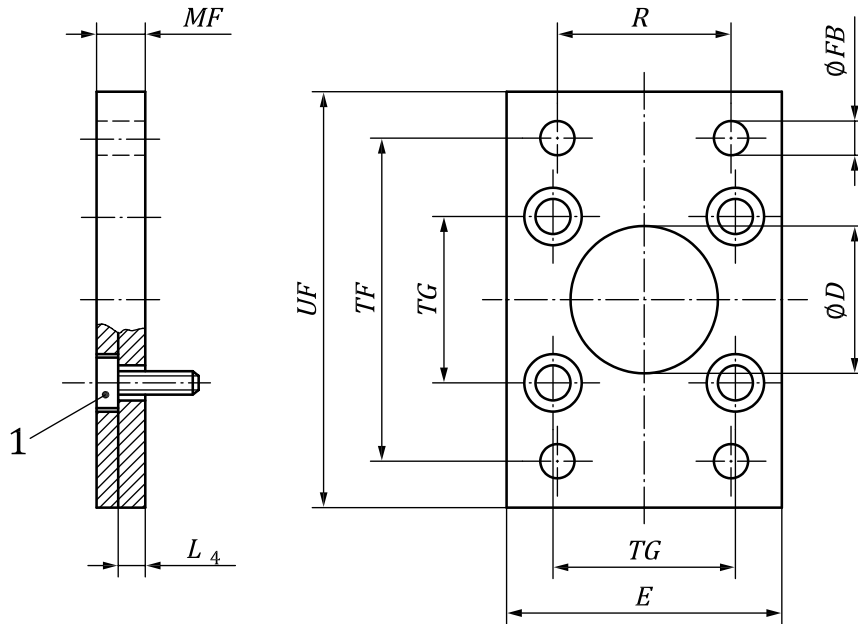

Key
1 cap screw

Figure 4 — Head, rectangular flange (MF1) and Cap, rectangular flange (MF2)

Table 4 — Dimensions of head and cap, rectangular flange (MF1 - MF2)

Dimensions in millimetres

AL	D	FB	TG		E	R	MF	TF	UF	L ₄	Cap screw size	W		ZF	
			nom	tol								nom	tol	nom	tol
32	30	7	32,5	±0,2	50	32	10	64	86	5,0	M6 × 20	16	±1,6	130	±1,25
40	35	9	38	±0,2	58	36	10	72	96	5,0	M6 × 20	20		145	
50	40	9	46,5	±0,2	70	45	12	90	115	6,5	M8 × 20	25		155	
63	45	9	56,5	±0,2	85	50	12	100	130	6,5	M8 × 20	25	±2	170	±1,6
80	45	12	72	±0,2	105	63	16	126	165	9,0	M10 × 25	30		190	
100	55	14	89	±0,2	130	75	16	150	187	9,0	M10 × 25	35		205	
125	60	16	110	±0,3	157	90	20	180	224	10,5	M12 × 25	45	±2,5	245	±2
160	65	18	140	±0,3	195	115	20	230	280	9,5	M16 × 30	60		280	
200	75	22	175	±0,3	238	135	25	270	320	12,5	M16 × 30	70		300	
250	90	26	220	±0,3	290	165	25	330	395	10,5	M20 × 30	80		330	
320	110	33	270	±0,3	353	200	30	400	475	15,0	M24 × 40	90		370	

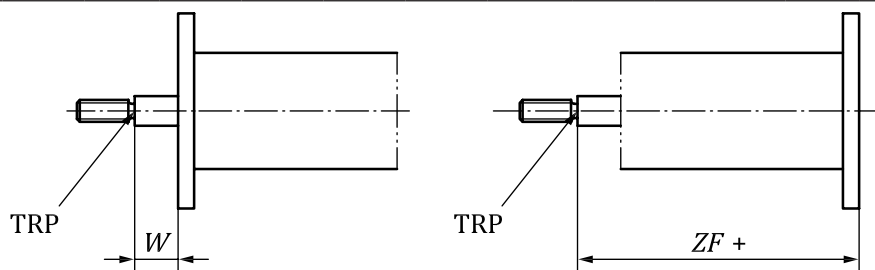

TRP Theoretical reference point.

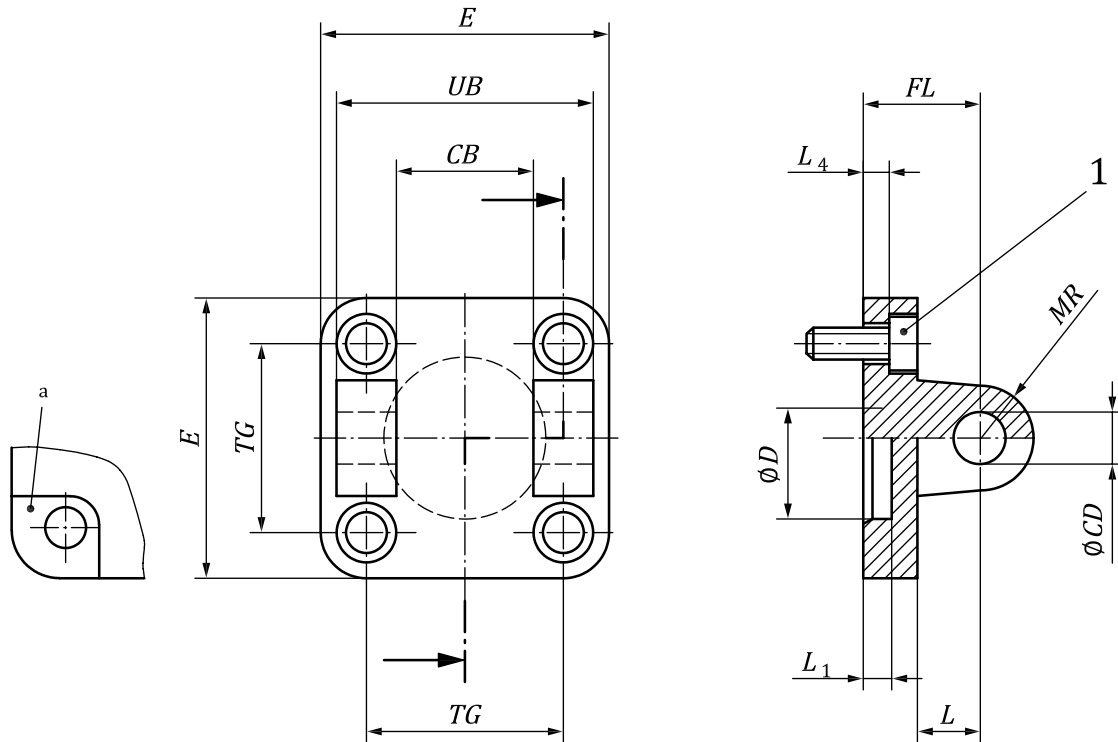

Key

- 1 cap screw
- a Optional open counterbore.

Figure 5 — Cap, detachable clevis (MP2)

Table 5 — Dimensions of cap, detachable clevis (MP2)

Dimensions in millimetres

AL	E max	UB h14	CB H14	TG		FL ±0,2	L ₁ min	L min	L ₄ ±0,5	D H11	CD H9	MR max	Cap screw size	XD	
				nom	tol									nom	tol
32	50	45	26	32,5	±0,2	22	4,5	12	5,5	30	10	11	M6 × 20	142	±1,25
40	58	52	28	38		25	4,5	15	5,5	35	12	13	M6 × 20	160	
50	70	60	32	46,5		27	4,5	15	6,5	40	12	13	M8 × 20	170	
63	85	70	40	56,5		32	4,5	20	6,5	45	16	17	M8 × 20	190	±1,6
80	105	90	50	72		36	4,5	20	10	45	16	17	M10 × 25	210	
100	130	110	60	89		41	4,5	25	10	55	20	21	M10 × 25	230	

Table 5 (continued)

AL	E max	UB h14	CB H14	TG		FL ±0,2	L ₁ min	L min	L ₄ ±0,5	D H11	CD H9	MR max	Cap screw size	XD	
				nom	tol									nom	tol
125	157	130	70	110	±0,3	50	7	30	10	60	25	26	M12 × 25	275	±2
160	195	170	90	140		55	7	35	10	65	30	31	M16 × 30	315	
200	238	170	90	175		60	7	35	11	75	30	31	M16 × 30	335	
250	290	200	110	220		70	11	45	11	90	40	41	M20 × 35	375	
320	353	220	120	270		80	11	50	15	110	45	46	M24 × 40	420	±2,5

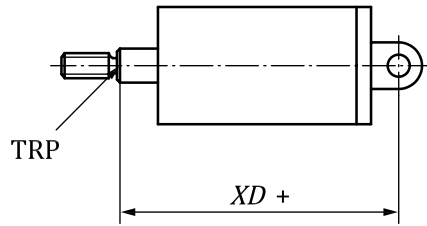

TRP Theoretical reference point.

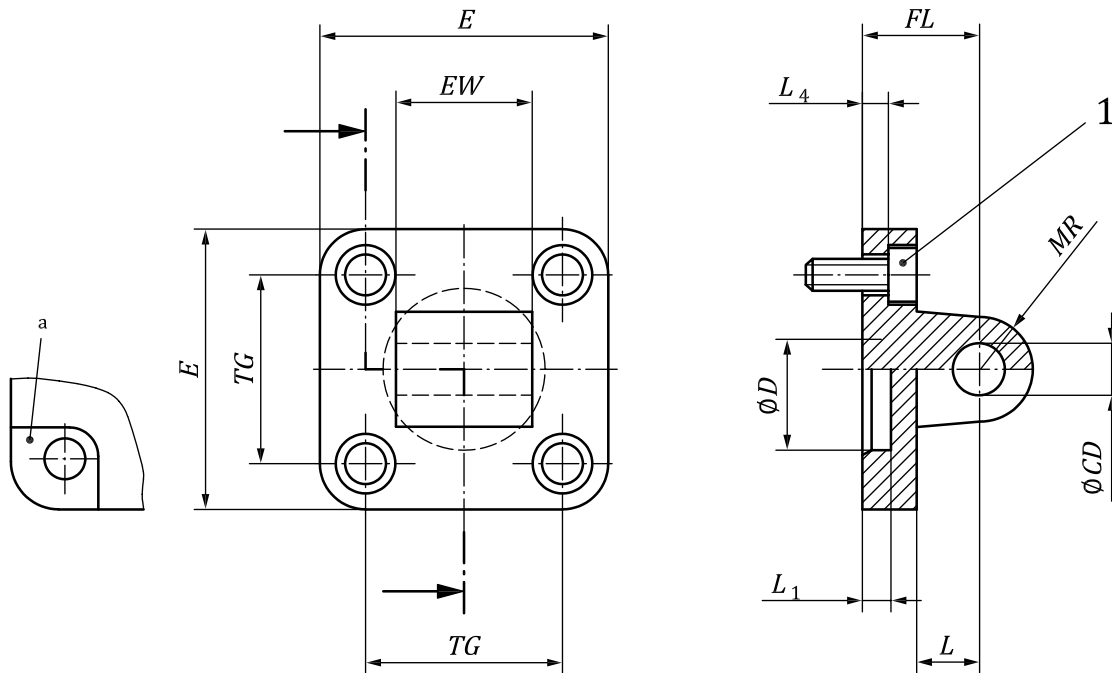

Key

- 1 cap screw
- a Optional open counterbore.

Figure 6 — Cap, detachable plain eye (MP4)

Table 6 — Dimensions of cap, detachable plain eye (MP4)

Dimensions in millimetres

AL	E		EW		TG		FL	L ₁	L	L ₄	D	CD	MR	Cap screw size		XD		
	max	nom	tol	nom	tol	±0,2	min	min	±0,5	H11	H9	max	nom	tol	nom	tol		
32	50	26	-0,2 -0,6	32,5	±0,2	22	4,5	12	5,5	30	10	11	M6 × 20	142	±1,25			
40	58	28		38		25	4,5	15	5,5	35	12	13	M6 × 20	160				
50	70	32		46,5		27	4,5	15	6,5	40	12	13	M8 × 20	170				
63	85	40		56,5		32	4,5	20	6,5	45	16	17	M8 × 20	190	±1,6			
80	105	50		72		36	4,5	20	10	45	16	17	M10 × 25	210				
100	130	60		89		41	4,5	25	10	55	20	21	M10 × 25	230				
125	157	70	-0,5 -1,2	110	±0,3	50	7	30	10	60	25	26	M12 × 25	275	±2			
160	195	90		140		55	7	35	10	65	30	31	M16 × 30	315				
200	238	90		175		60	7	35	11	75	30	31	M16 × 30	335				
250	290	110		220		70	11	45	11	90	40	41	M20 × 35	375	±2,5			
320	353	120		270		80	11	50	15	110	45	46	M24 × 40	420				

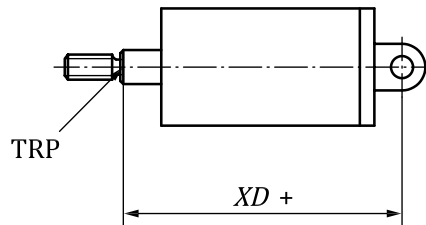

TRP Theoretical reference point.

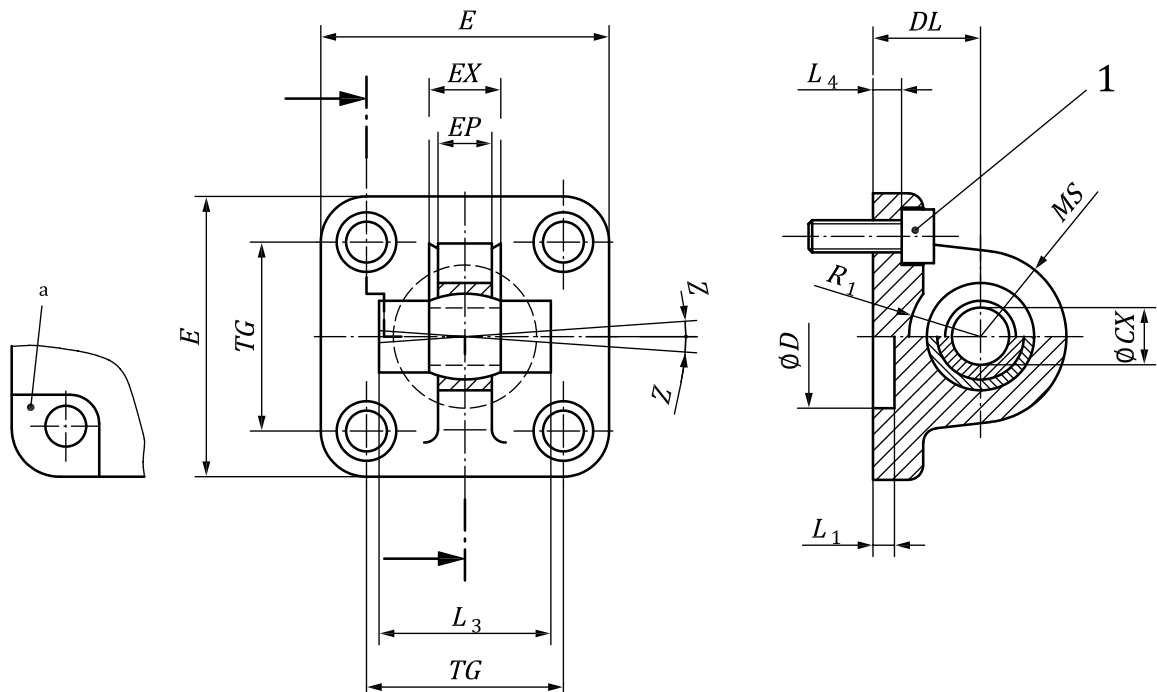

Key

- 1 cap screw
- a Optional counterbore.

Figure 7 — Cap, detachable eye with spherical bearing (MP6)

Table 7 — Dimensions of cap, detachable eye with spherical bearing (MP6)

Dimensions in millimetres

AL	CX	E	EX	MS	EP	DL	R1	TG		D	L ₁	L ₄	L ₃	Cap screw size	XN		Z
								nom	tol						nom	tol	
32	10	50	14	18	10,5	22	12	32,5	±0,2	30	4,5	5,5	36	M6 × 20	142	±1,25	4°
40	12	58	16	18	12	25	14	38	±0,2	35	4,5	5,5	42	M6 × 20	160		
50	16	70	21	21	15	27	19	46,5	±0,2	40	4,5	6,5	48	M8 × 20	170		
63	16	85	21	23	15	32	19	56,5	±0,2	45	4,5	6,5	55	M8 × 20	190	±1,6	
80	20	105	25	28	18	36	24	72	±0,2	45	4,5	10	70	M10 × 25	210		
100	20	130	25	30	18	41	24	89	±0,2	55	4,5	10	80	M10 × 25	230	±2	
125	30	157	37	40	25	50	32	110	±0,3	60	7	10	100	M12 × 25	275		
160	35	195	43	44	30	55	38	140	±0,3	65	7	10	125	M16 × 30	315		
200	35	238	43	47	30	60	40	175	±0,3	75	7	11	125	M16 × 30	335	±2,5	
250	40	290	49	53	35	70	44	220	±0,3	90	11	11	130	M20 × 35	375		
320	50	353	60	63	45	80	54	270	±0,3	110	11	15	160	M24 × 40	420		

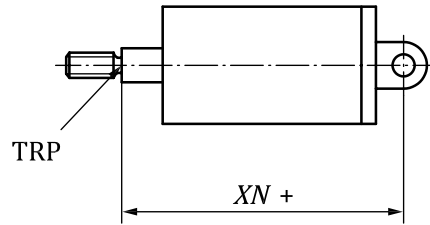

TRP Theoretical reference point.

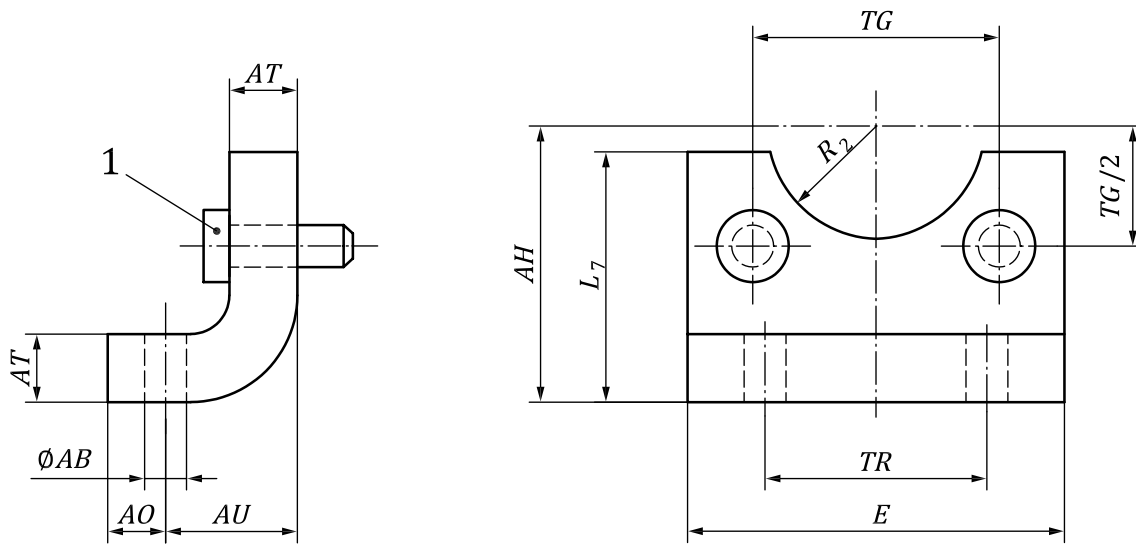

Key

- 1 cap screw

Figure 8 — End angles (MS1)

Table 8 — Dimensions of end angles (MS1)

Dimensions in millimetres

AL	AB	TG		E	TR	AO	AU	AH	L ₇		AT		R ₂	Cap screw size	SA		XA	
		nom	tol						max	JS14	max	±0,2			JS16	nom	tol	nom
32	7	32,5	±0,2	50	32	11	24	32	32	0 -12	4	±0,3	15	M6 × 16	142	±1,25	144	±1,25
40	10	38		58	36	15	28	36	36	0 -12	4		17,5	M6 × 16	161		163	
50	10	46,5		70	45	15	32	45	45	0 -14	5		20	M8 × 20	170		175	
63	10	56,5		85	50	15	32	50	50	0 -16	5	±0,5	22,5	M8 × 20	185	±1,6	190	±1,6
80	12	72		105	63	20	41	63	63	0 -19	6		22,5	M10 × 20	210		215	
100	14,5	89		130	75	25	41	71	71	0 -19	6		27,5	M10 × 20	220		230	
125	16,5	110	±0,3	157	90	25	45	90	90	0 -21	8	±1	30	M12 × 25	250	±2	270	±2
160	18,5	140		195	115	25	60	115	115	0 -23	10		32,5	M16 × 30	300		320	
200	24	175		238	135	35	70	135	135	0 -26	12		37,5	M16 × 30	320		±2	
250	28	220		290	165	40	75	165	165	0 -31	20	45	M20 × 40	350	380			
320	35	270		353	200	45	85	200	200	0 -38	23	55	M24 × 45	390	±2,5	425	±2,5	

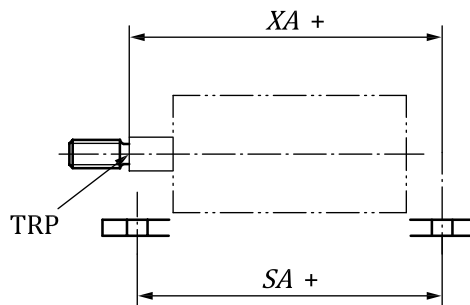

TRP Theoretical reference point.

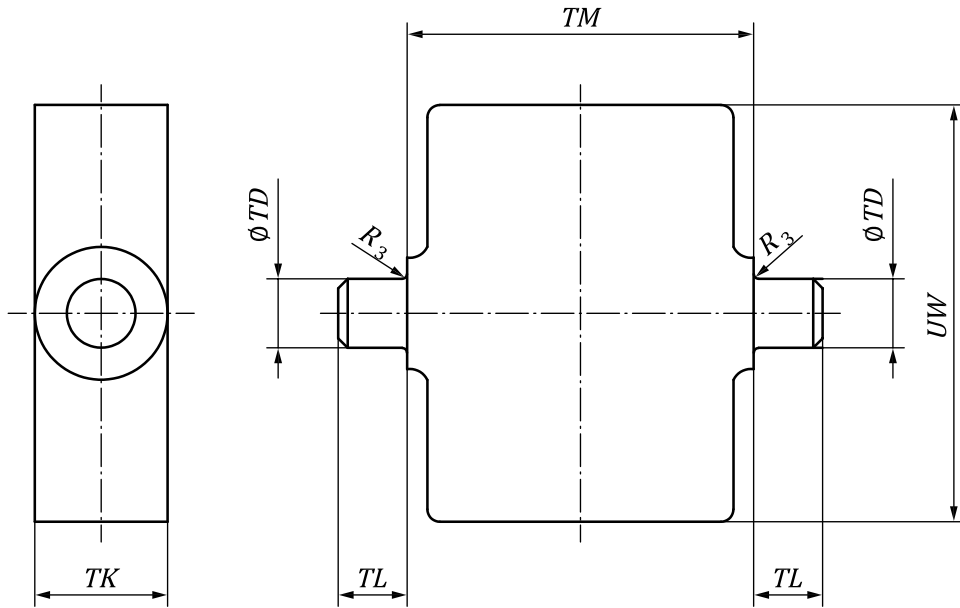
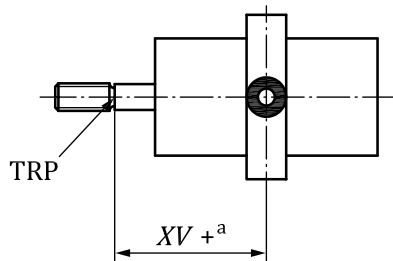

Figure 9 — Intermediate fixed or movable trunnions (male) (MT4)

Table 9 — Dimensions of intermediate fixed or movable trunnions (male) (MT4)

Dimensions in millimetres

<i>AL</i>	<i>TM</i> h14	<i>UW</i> max	<i>TL</i> h14	<i>TK</i> max	<i>TD</i> e9	<i>R₃</i> max	<i>XV</i> min
32	50	65	12	25	12	1	73
40	63	75	16	28	16	1,6	82,5
50	75	95	16	28	16	1,6	90
63	90	105	20	36	20	1,6	97,5
80	110	130	20	36	20	1,6	110
100	132	145	25	48	25	2	120
125	160	175	25	50	25	2	145
160	200	220	32	50	32	2,5	170
200	250	260	32	50	32	2,5	185
250	320	320	40	60	40	3,2	205
320	400	400	50	70	50	3,2	230



^a $XV \text{ max} = XV \text{ min} + \text{stroke}$.

TRP Theoretical reference point.

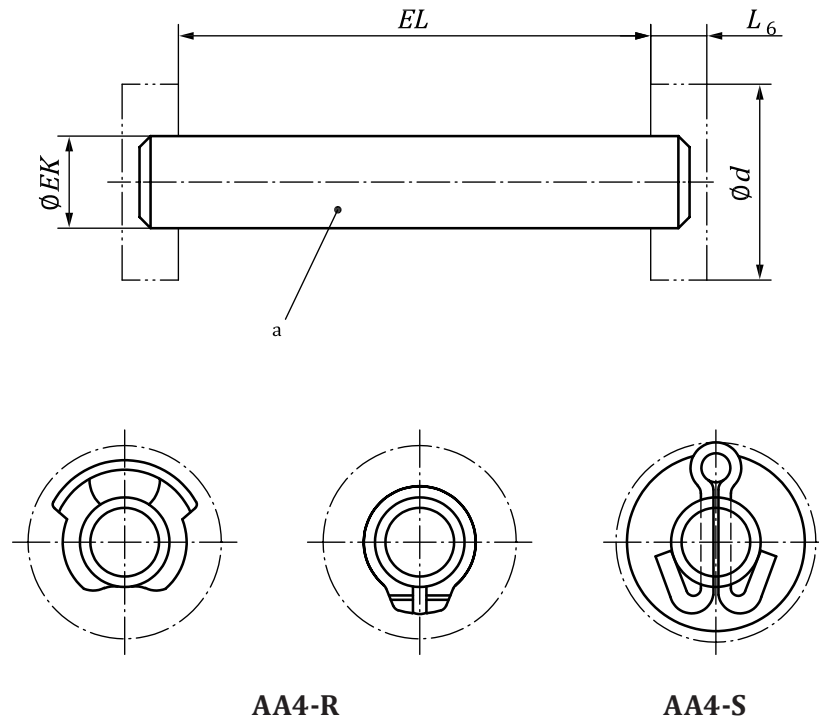

Examples of retaining methods (both ends)

a This pin is used with MP2, MP4 and AB7 mountings.

Figure 10 — Pivot pin, plain (AA4-R and AA4-S)

Table 10 — Dimensions of pivot pin, plain (AA4-R and AA4-S)

Dimensions in millimetres

<i>AL</i>	<i>d</i> max	<i>EK</i> e8	<i>EL</i>		<i>L₆</i> max
			nom	tol	
32	23	10	46	+2 0	9
40	25	12	53		9
50	25	12	61		9
63	32	16	71		11
80	32	16	91		11
100	40	20	111		11
125	50	25	132	+3 0	11
160	62	30	172		17
200	62	30	172		17
250	72	40	202		22
320	85	45	222		22

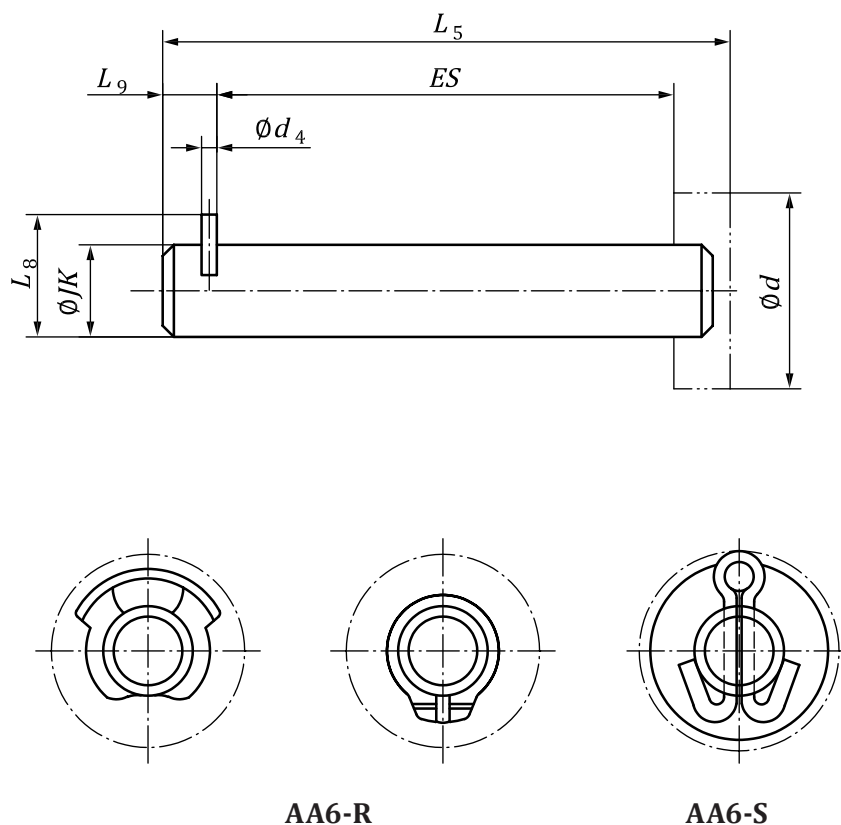

Example of retaining methods (only for the right-hand side)

Figure 11 — Pivot pin, spherical bearing (AA6-R and AA6-S)

Table 11 — Dimensions of pivot pin, spherical bearing (AA6-R and AA6-S)

Dimensions in millimetres

<i>AL</i>	<i>d</i> max	<i>JK</i> h9	<i>ES</i>		<i>L5</i> max	<i>L9</i> Js13	<i>L8</i> Js13	<i>d4</i> h12
			nom	tol				
32	23	10	31	+0,2 0	46	4,5	14	3
40	25	12	36		53	6	16	4
50	25	16	41		58	6	20	4
63	32	16	47		66	6	20	4
80	32	20	61		80	6	24	4
100	40	20	71		90	6	24	4
125	50	30	91	+0,3 0	114	9	36	6
160	62	35	116		145	9	41	6
200	62	35	116		145	9	41	6
250	72	40	117		155	12	48	8
320	85	50	142		180	12	58	8

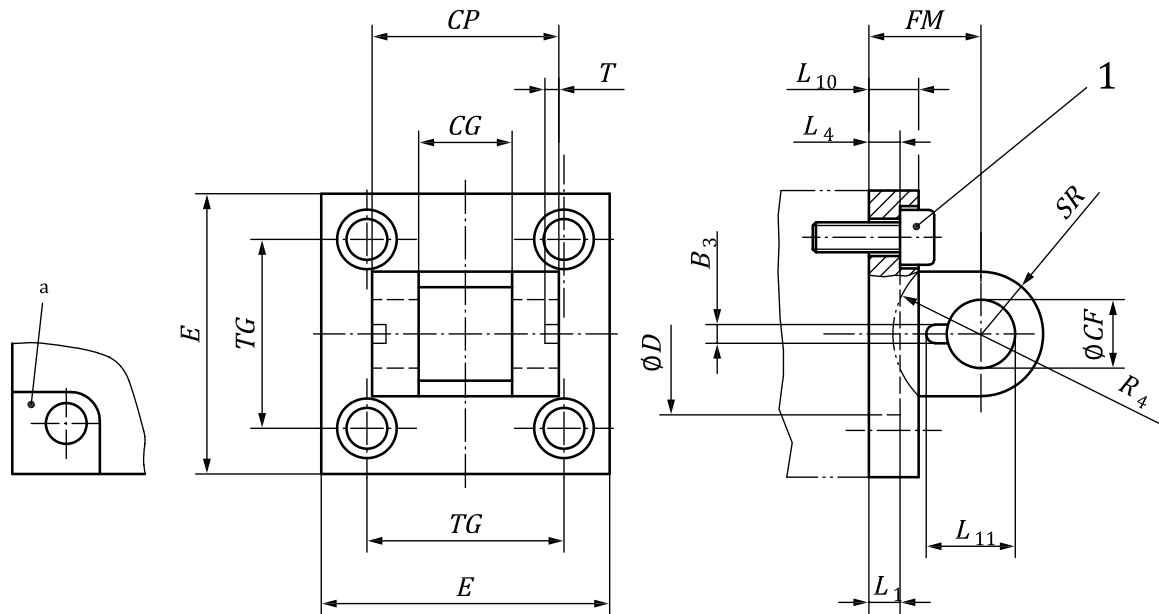

Key

- 1 cap screw
- a Optional open counterbore.

Figure 12 — Clevis bracket, spherical eye, straight (AB6)

Table 12 — Dimensions of clevis bracket, spherical eye (AB6)

Dimensions in millimetres

AL	B ₃	CF	CG	CP	E	FM	L ₁₁	SR	T	TG		D	L ₁	L ₄	L ₁₀	R ₄	Cap screw size	XD	
										nom	tol							nom	tol
32	±0,2	F7	D10	d12	max	±0,2	⁰ _{-0,5}	max	±0,2	nom	tol	H11	min	±0,5	max		M6 × 20	142	±1,25
40	4,3	12	16	40	58	25	18	13	4	38	±0,2	35	4,5	5,5	10	20	M6 × 20	160	
50	4,3	16	21	45	70	27	23	18	4	46,5	±0,2	40	4,5	6,5	12	22	M8 × 20	170	
63	4,3	16	21	51	85	32	23	18	4	56,5	±0,2	45	4,5	6,5	12	25	M8 × 20	190	±1,6
80	4,3	20	25	65	105	36	27	22	4	72	±0,2	45	4,5	10	16	30	M10 × 25	210	
100	4,3	20	25	75	130	41	27	22	4	89	±0,2	55	4,5	10	16	32	M10 × 25	230	
125	6,3	30	37	97	157	50	40	30	6	110	±0,3	60	7	10	20	42	M12 × 25	275	±2
160	6,3	35	43	122	195	55	45	36	6	140	±0,3	65	7	10	20	46	M16 × 30	315	
200	6,3	35	43	122	238	60	45	38	6	175	±0,3	75	7	11	25	49	M16 × 30	335	
250	8,3	40	49	125	290	70	53	42	8	220	±0,3	90	11	11	25	55	M20 × 35	375	
320	8,3	50	60	150	353	80	63	52	8	270	±0,3	110	11	15	30	65	M24 × 40	420	

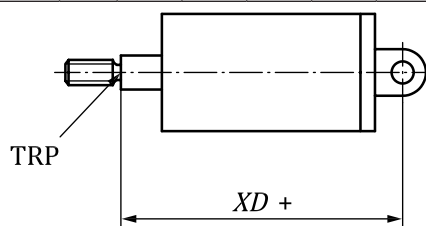

TRP Theoretical reference point.

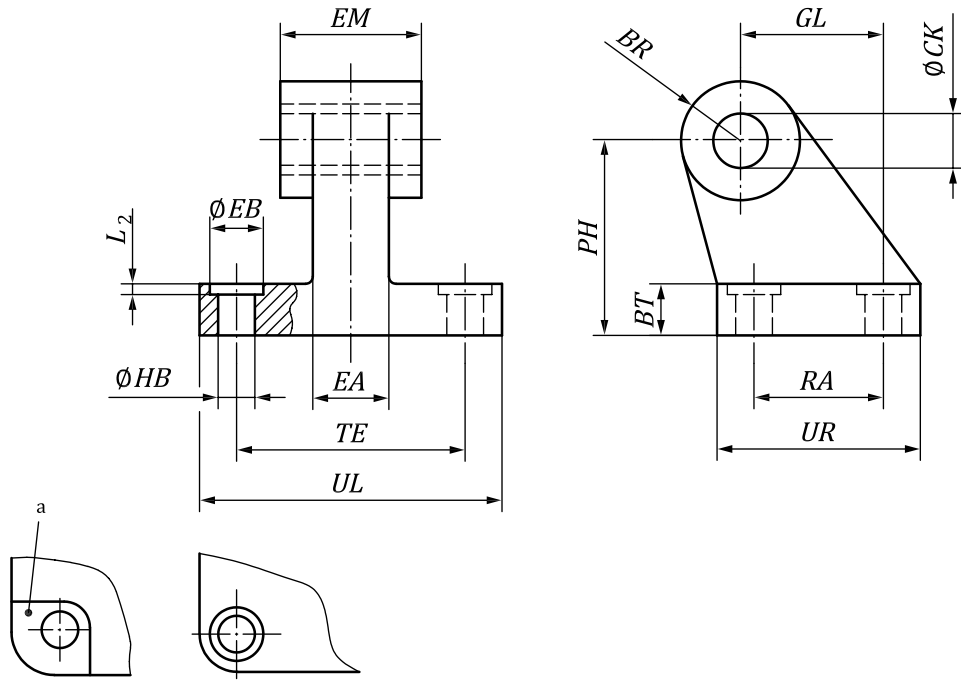

Key
 a Optional open counterbore.

Figure 13 — Eye bracket, in angle (AB7)

Table 13 — Dimensions of eye bracket, in angle (AB7)

Dimensions in millimetres

AL	EB min	CK H9	HB H13	TE JS14	UL max	EA max	GL JS14	L ₂ max	RA JS14	EM		UR max	PH JS15	BT	BR max
										nom	tol				
32	11	10	6,6	38	51	10	21	1,6	18	26	-0,2 -0,6	31	32	8	10
40	11	12	6,6	41	54	12	24	1,6	22	28		35	36	10	11
50	15	12	9	50	65	16	33	1,6	30	32		45	45	12	13
63	15	16	9	52	67	16	37	1,6	35	40		50	50	12	15
80	18	16	11	66	86	20	47	2,5	40	50		60	63	14	15
100	18	20	11	76	96	20	55	2,5	50	60		70	71	15	19
125	20	25	14	94	124	30	70	3,2	60	70	-0,5 -1,5	90	90	20	22,5
160	20	30	14	118	156	36	97	4	88	90		126	115	25	31,5
200	26	30	18	122	162	40	105	4	90	90		130	135	30	31,5
250	33	40	22	150	200	45	128	4,5	110	110		160	165	35	40
320	40	45	26	170	234	55	150	4,5	122	120		186	200	40	45

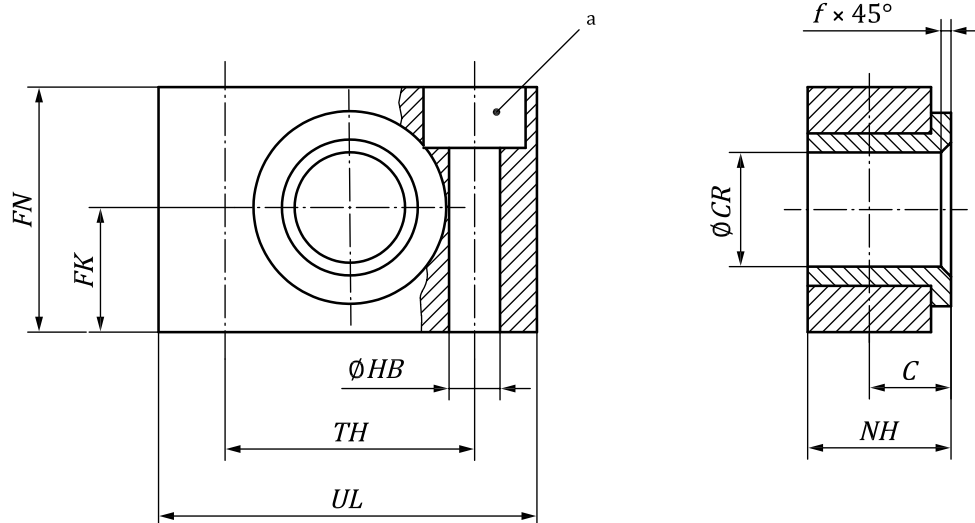

Key

a Counterbore for screw according to ISO 273.

Figure 14 — Trunnion bracket (AT4)

Table 14 — Dimensions of trunnion bracket (AT4)

Dimensions in millimetres

AL	UL	NH	TH		C	CR H9	HB H13	FN	FK		f × 45° min	
			nom	tol					nom	tol		
32	46	18	32	±0,2	10,5	12	6,6	30	15	±0,1	1	
40	55	21	36		12	16	9	36	18		1,6	
50	55	21	36		12	16	9	36	18		1,6	
63	65	23	42		13	20	11	40	20		1,6	
80	65	23	42		13	20	11	40	20		1,6	
100	75	28,5	50		16	25	14	50	25		2	
125	75	28,5	50	±0,3	16	25	14	50	25	±0,2	2	
160	92	40	60		22,5	32	18	60	30		2,5	
200	92	40	60		22,5	32	18	60	30		2,5	
250	140	50	90		27,5	40	22	70	35		3,2	
320	150	60	100		32,5	50	26	80	40		40	3,2

Bibliography

- [1] ISO 6099, *Fluid power systems and components — Cylinders — Identification code for mounting dimensions and mounting types*

